

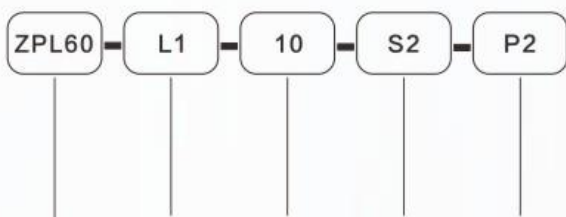

### REDUCER MODEL, SELECTION INSTRUCTIONS MODEL REPRESENTATION

#### ● 减速机型号、选型说明型号表示



产品系列规格	级数	减数比	输出轴方式	精度等级
Product Series	Series	Ratio	output method	Precision
60	L1:一级	3	S2:单键轴	P2:标准
90	L2:二级	4	S1:光轴	P1:精密
120		5	K:空心单键轴	
		7		
		10		
		15		
		20		
		25		
		30		
		35		
		40		
		....		
		100		

### SPEED REDUCER SELECTION INSTRUCTIONS

#### ● 减速机选型须知

- 机种、型号、扭矩
- 减速比或者出力轴转速
- 工况及连接方式
- 数量及安装的机械名称
- 入力方式和入力转速
- 电机厂牌型号或者法兰及电机轴尺寸
- model, model, polycarbonate
- reduction ratio or output shaft axial
- working conditions and connection methods
- Quantity and installed machine name
- Incoming mode and input transformation
- Motor brand model or flange and motor shaft size

技术参数  
Technical parameter

规格 Specifications			ZPL60	ZPL90	ZPL120		
	级数 Series	比数 Gear ratio					
额定扭矩 T <sub>N</sub> (Nm)	L1	3	22	96	155		
		4	34	122	216		
		5	35	122	223		
		7	27	95	164		
		10	16	56	90		
	L2	12	28	96	206		
		15	28	96	155		
		16	35	122	230		
		20	35	122	230		
		25	37	122	237		
		28	35	122	230		
		30	25	96	164		
		35	35	122	237		
		40	35	122	230		
		50	37	122	237		
		70	30	95	174		
		100	16	56	90		
		最大输出扭矩T <sub>2N</sub> (Nm) The maximum output torque			2倍额定扭矩输出 2x rated torque output		
		满载效率(%) Full-load efficiency			L1≥96% L2≥92%		
平均使用寿命(h) Average service life			20000				
工作温度(°C) Working temperature			-20°C~+80°C				
防护等级 Level of protection			IP65				
安装方向 Installation direction			任意方向 Arbitrary direction				
重量(Kg) Weight (Kg)	L1		1.75	4.95	10.45		
	L2		2.05	6	12.55		

ZF  
PL  
PNF  
PWE  
ZPF  
ZPL  
PFK  
ZPK  
ZPNF  
ZPWE  
PFC 29F  
42-PFS  
ZPFS150  
SHD  
Z260  
Z1Z90  
ZK90

## 技术参数 Technical parameter

规格 Specifications			ZPL60	ZPL90	ZPL120		
最大输入转速 n1N Maximum input speed		rpm	8000	6000	4800		
额定输入转速 n1B Rated input speed		rpm	4000	3500	3000		
最大容许径向力 F2rB The maximum allowable radial force		N	320	680	1730		
最大容许轴向力 F2aB The maximum allowable axial force		N	260	620	1270		
抗扭刚性 Torsional rigidity		Nm/arcmin	2	6.2	11.1		
噪音值 Noise value		dB	≤58	≤60	≤65		
回程间隙 Return stroke clearance	P1	L1	arcmin	≤8	≤8	≤8	
		L2	arcmin	≤12	≤12	≤12	
	P2	L1	arcmin	≤16	≤16	≤16	
		L2	arcmin	≤20	≤20	≤20	
	转动惯量 Moment of inertia	L1	3	Kg.cm <sup>2</sup>	0.28	1.55	7.3
			4	Kg.cm <sup>2</sup>	0.27	1.5	7
			5	Kg.cm <sup>2</sup>	0.27	1.49	6.97
			7	Kg.cm <sup>2</sup>	0.25	1.24	6.26
			10	Kg.cm <sup>2</sup>	0.25	1.24	6.24
		L2	12	Kg.cm <sup>2</sup>	0.27	1.33	6.92
			15	Kg.cm <sup>2</sup>	0.26	1.31	6.9
			16	Kg.cm <sup>2</sup>	0.27	1.3	6.74
			20	Kg.cm <sup>2</sup>	0.27	1.28	6.67
			25	Kg.cm <sup>2</sup>	0.27	1.28	6.67
L2	28	Kg.cm <sup>2</sup>	0.27	1.27	6.66		
	30	Kg.cm <sup>2</sup>	0.25	1.27	6.66		
	35	Kg.cm <sup>2</sup>	0.25	1.27	6.65		
	40	Kg.cm <sup>2</sup>	0.27	1.27	6.65		
	50	Kg.cm <sup>2</sup>	0.22	1.1	6.3		
L2	70	Kg.cm <sup>2</sup>	0.22	1.1	6.3		
	100	Kg.cm <sup>2</sup>	0.22	1.1	6.3		

# ZPL

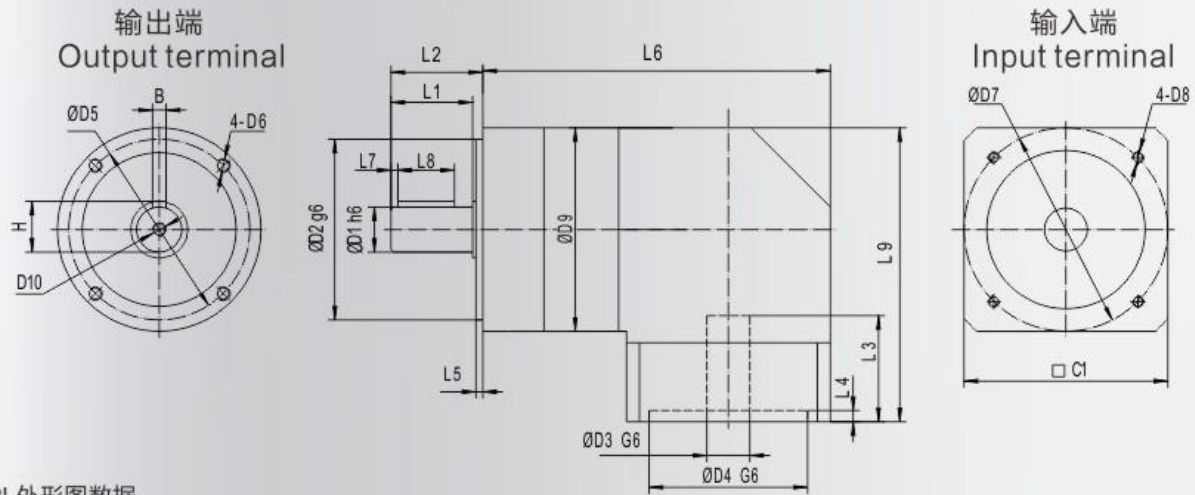

ZPL外形图数据  
ZPL outline drawing data

级数	规格	D1	D2	D3	D4	D5	D6	D7	D8	D9	D10	L1	L2	L3	L4	L5	L6	L7	L8	L9	C1	B	H
单级 L1	ZPL60	14	40	14	50	52	M5	70	M4	60	M5	31	35	31.5	5	3	111.5	3	20	100.5	60	5	16
		14	40	11	50	52	M5	70	M4	60	M5	31	35	31.5	5	3	111.5	3	20	100.5	60	5	16
		14	40	8	38.1	52	M5	66.7	M4	60	M5	31	35	31.5	5	3	111.5	3	20	100.5	60	5	16
		14	40	8	36	52	M5	70.7	M4	60	M5	31	35	31.5	5	3	111.5	3	20	100.5	60	5	16
	ZPL90	20	68	19	70	80	M6	90	M5	90	M6	36	40.5	47	5	3	153.5	3	25	130	90	6	22.5
		20	68	16	80	80	M6	100	M5	90	M6	36	40.5	47	5	3	153.5	3	25	130	90	6	22.5
		20	68	14	73	80	M6	98.43	M5	90	M6	36	40.5	47	5	3	153.5	3	25	130	90	6	22.5
		20	68	14	60	80	M6	98.43	M5	90	M6	36	40.5	47	5	3	153.5	3	25	130	90	6	22.5
	ZPL120	25	80	22	110	100	M10	145	M8	120	M10	48.5	54	59.5	8	4	191	5	40	160.8	120	8	28
		25	80	24	110	100	M10	145	M8	120	M10	48.5	54	59.5	8	4	191	5	40	160.8	120	8	28
		25	80	19	95	100	M10	115	M8	120	M10	48.5	54	59.5	8	4	191	5	40	160.8	120	8	28
		25	80	19	95	100	M10	130	M8	120	M10	48.5	54	59.5	8	4	191	5	40	160.8	120	8	28
双级 L2	ZPL60	14	40	14	50	52	M5	70	M4	60	M5	31	35	31.5	5	3	127.5	3	20	100.5	60	5	16
		14	40	11	50	52	M5	70	M4	60	M5	31	35	31.5	5	3	127.5	3	20	100.5	60	5	16
		14	40	8	38.1	52	M5	66.7	M4	60	M5	31	35	31.5	5	3	127.5	3	20	100.5	60	5	16
		14	40	8	36	52	M5	70.7	M4	60	M5	31	35	31.5	5	3	127.5	3	20	100.5	60	5	16
	ZPL90	20	68	19	70	80	M6	90	M5	90	M6	36	40.5	47	5	3	177.5	3	25	130	90	6	22.5
		20	68	16	80	80	M6	100	M5	90	M6	36	40.5	47	5	3	177.5	3	25	130	90	6	22.5
		20	68	14	73	80	M6	98.43	M5	90	M6	36	40.5	47	5	3	177.5	3	25	130	90	6	22.5
		20	68	14	60	80	M6	98.43	M5	90	M6	36	40.5	47	5	3	177.5	3	25	130	90	6	22.5
	ZPL120	25	80	22	110	100	M10	145	M8	120	M10	48.5	54	59.5	8	4	222	5	40	160.8	120	8	28
		25	80	24	110	100	M10	145	M8	120	M10	48.5	54	59.5	8	4	222	5	40	160.8	120	8	28
		25	80	19	95	100	M10	115	M8	120	M10	48.5	54	59.5	8	4	222	5	40	160.8	120	8	28
		25	80	19	95	100	M10	130	M8	120	M10	48.5	54	59.5	8	4	222	5	40	160.8	120	8	28
ZPL120	25	80	19	85	100	M10	132	M8	120	M10	48.5	54	59.5	8	4	222	5	40	160.8	120	8	28	

ZF  
PL  
PNF  
PWE  
ZPF  
ZPL  
PFK  
ZPKF  
ZPNF  
ZPWE  
PFC ZPF  
42 PFS  
ZPFS150  
SHD  
Z260  
ZT290  
ZK90